

# Immortals 2011 Team Description Paper

Iran University of Science and Technology

Mohammad Reza Niknejadi<sup>1</sup>, Seyed Ali Salehi Neyshabouri<sup>2</sup>, Seyed Ali GhaziMirSaeed<sup>3</sup>, Ehsan Kamali<sup>4</sup>,  
Mohammad Hossein Fazeli<sup>5</sup>, Yousof Piran<sup>1</sup>, Mustafa Talaezadeh Khouzani<sup>6</sup>,

<sup>1</sup> Department of Computer Engineering of Iran University of Science and Technology

<sup>2</sup> Department of IT Engineering of Sharif University

<sup>3</sup> Department of Mechanical Engineering of Tehran University

<sup>4</sup> Department of Electronic Engineering of Shahed University

<sup>5</sup> Department of Mechanical Engineering of Iran University of Science and Technology

<sup>6</sup> Department of Computer Engineering of Shahid Beheshti University

**Abstract.** Below, we have classified information in 4 major parts: mechanics, electronics, programming and vision. Pictures of available instruments are attached and further information about future improvements is added.

## 1 Introduction

“Immortals” is a robotic team consisting of university students of Sharif, Tehran, IUST, Shahed and Shahid Beheshti Universities. The team was formed in 2003 to attend junior soccer league competitions. The team successfully participated the 3rd Hellicup Robotic competitions in 2004. After placing 3rd we qualified for 2005 Osaka Robocup, taking part under the name Robonik. The team also successfully participated IranOpen Robotic competitions in 2006 & Iran Open 2007. The small size project started in summer 2007 and simple-structured robots were made by summer 2008 and have continually improved since then. After participating Robocup 2009 Graz and Robocup 2010 Singapore competitions, it was decided to gear up for the next competitions with revising the whole Mechanical system and equipping the robot with a sophisticated electronic system to extract the maximum efficiency and maneuverability from the robots. Inheriting all preceding robots’ strengths while decreasing their weaknesses, a brand new generation of robots is set to participate the Robocup 2011 competitions.

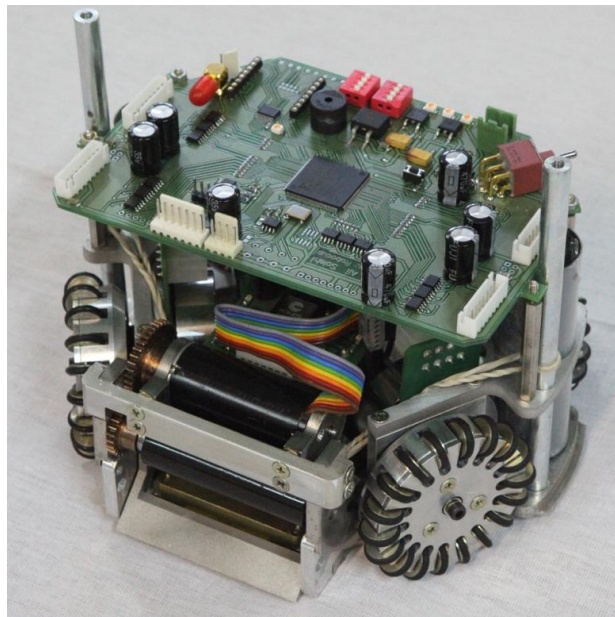

Fig.1. current Immortals Robots

## 2 Mechanics

The main chassis consists of a 5mm hard anodized 7075 aluminum alloy plate on which motors, batteries, encoders, capacitors, and kicker systems are mounted. Robots are covered by a carbon-fiber compound that is light as it is solid.

To stabilize movements and kicks mechanically, the altitude of the center of mass is lowered. It is achieved by arranging rather heavy parts on the plate, that level first in the whole robots structures.

The robots' overall height is 148mm and its diameter is 178mm. The gearbox is merged into wheels to minimize the volume occupied by driving system. Its design is unique so that the gear used for transition is carved into the wheel itself.

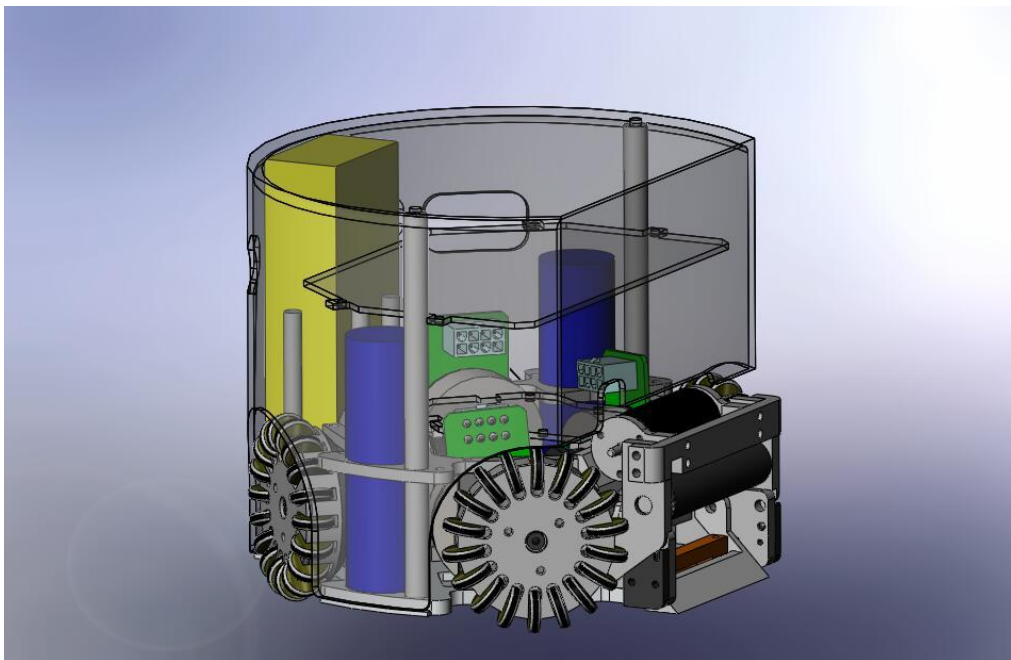

Fig.2. 3D figure of the Immortals robots base

### 2.1 Wheels

Robots are designed Omni-directional by four Omni-wheels. Each wheel is 61mm in diameters and has 18 rollers covered by double sealed O-rings for better grip. Both wheels and rollers are made of 7075 aluminum alloy. As there is a possibility of field enlargement, higher speeds are inevitable; so the gear ratio is optimized to 45:12 and 50 Watts Maxon EC-45 brushless motors are used to overcome the max-speed/max-acceleration trade off. The gear is merged with wheel, carved into it, to avoid vibrations.

## **2.2 Dribbler**

Dribbler is made up of an 8mm Silicon tube actuated by a 25 Watts Maxon EC-Max-22 brushless motor connected by a gear of 26:45 ratio to the tube's shaft which spins back with 7000 to 17000 RPM depending on AI commands. A servo-motor adjusts the height dribbler to avoid unwanted collisions of the ball with the Silicon tube during the kicking process. It is done by rotating the dribbler around its horizontal axis along the shaft by approximately 7 degrees.

## **2.3 Kicker**

The most important aspect in designing a kicking system is to optimize the solenoid. The more efficient the solenoid gets, the less time and energy would be needed to charge the capacitors and the lighter and smaller the module becomes. Parameters to change in order to optimize a solenoid are the plunger diameter, outer diameter, wire diameter, length of the core and the shield, the shape of the system and the material used in the wire, plunger and the outer shield. After experimenting numerous types of solenoid systems, we eventually obtained the desired efficiency using a 1020-steel cylinder-shaped outer shield, a core made of 1020-steel used as the plunger and a copper coil. The outer shield is attached to the bottom chassis which acts like a huge heat-sink for extracting heat. The material used in the chip-kicking system is the same as that of the round one and the only difference between the solenoids is in geometrical parameters.

## **3 Electronics**

A Xilinx XC3S400 chip functions as the only processor on the main board and operates telecommunication, decodes IR sensors data, drives motors and executes PID controller. This chip was chosen because of its low power consumption and its huge logic gate numbers in comparison with other similar products. Below different electronic parts of the project are described.

### **3.1 Motor Driving**

The motor driver is a 3- phase inverter circuit that drives 3-phase Brushless DC (BLDC) motors. This Robot is composed of 5 BLDC motors. Four of them are used for robot's Omni-directional wheels actuators and one for dribbling the ball. The input signals from the motor are two digital quadrature encoder feedback signals and three built-in hall sensors' signal. These signals are used for commutating BLDC motors. The output signals from commutation module to the driving circuit are delivered to 3 dual MOSFET-driver ICs, each driving a MOSFET in order to switch the current flowing through each stator coil of the BLDC motor. To control the movement of the robot, the PID controller is applied to the driver module implemented in the FPGA to control four motors used as Omni-directional drivers. This module combines with encoder sub-module, PID calculation sub-module, and motor driving sub-module. Firstly, the robot receives velocity commands from the AI system which consist of velocities in XY-

coordination and one angular velocity. Next, the main processor module translates velocities and rotation command into velocity of each wheel. Then, the main processor module sends each wheel its command respectively. The velocities measured by encoders are sent to the PID module to calculate the final velocity for each motor. That will make the motor rotate with an updated velocity as desired.

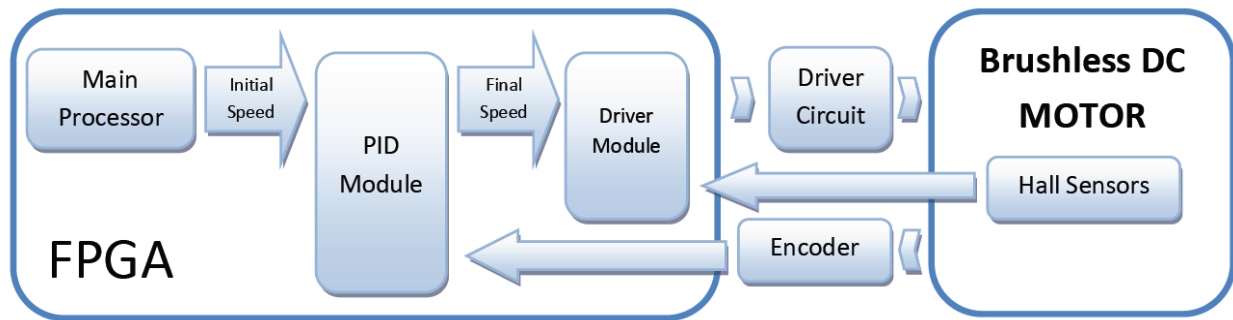

Fig.3. Schematic view of the driving system

### 3.2 Shooting System

Shooting module implemented in FPGA is used for sending pulse, charging, and opening IGBT gate which enables current flow from capacitor through solenoid. A boost converter circuit is used for charging system. Pulse generated by FPGA is used to switch the node of the boost converter. Four 1200uf capacitors are charged up to 200 Volts. Capacitor voltage is controlled by a comparator logic using an operational amplifier.

### 3.3 Dribbling System

The robot uses a Maxon EC-MAX 22 to dribble the ball. Dribbler module in FPGA is used to adjust the spinning bar speed by generating the PWM signal and to control the motor torque using PI controller. It also adjusts the height of the spinning tube by controlling the servo motor contrived in the robot better control the ball.

### 3.4 Wireless Communication

Robots use Telecontrolli RXQ2-GFSK multi-channel radio transceiver, operating within the 440 MHz band. The module operates in user selectable channels.

## 4 Software

The overall software architecture is to take information of the field from SSL-Vision over network, filter this information and pass them to the AI. The AI calculates a target for each robot. Finally, it transmits the processed data to the robots, in each frame.

## **4.1 Calculating Word State**

Kalman filter is used for reducing noises, and predicting the future state. There are two types of input for the filter. For our robots, we use the data that is sent to the robots each frame, and for the ball and opponent robots, vision-calculated data is used.

## **4.2 Decision Making**

The main method for this part is STP, developed by CMDragons and is tested since 2003, and the results show the success of this method. In an adversarial multi-robot task, such as playing robot soccer, decisions for team and single robot behavior must be made quickly to take advantage of short-term fortuitous events when they occur. When no such opportunities exist, the team must execute sequences of coordinated action across team members to increase the likelihood of future opportunities. A hierarchical architecture is developed, called STP, to control an autonomous team of robots operating in an adversarial environment. STP consists of Skills for executing the low-level actions that make up robot behavior and tactics for determining which skills to execute, and Plays for coordinating synchronized activity amongst team members.

### **4.2.1 Path planning**

The challenge of finding an optimized and reliable path dates back to emersion of mobile robots. Several approaches have been developed that have partially answered this need. Satisfying results in previous implementations has led to an increased utilization of sampling-based motion planning algorithms in recent years, especially in high degrees of freedom (DOF), fast evolving environments. Another advantage of these algorithms is their probabilistic completeness that guarantees delivery of a path in sufficient time, if one exists.

On the other hand, sampling based motion planners leave no comment on safety of the planned path. The SB-RRT method used this year suggests biasing the Rapidly-exploring Random Trees (RRTs), with the outcome of a safety evaluation, which affects the probability of choosing a random point in the sampling phase of the RRT algorithm, to increase the chance of safer outcomes. By parallelizing this algorithm and multifold execution of it on the Graphics Processing Unit (GPU) with various probabilities for moving to a safer state, a near-optimal solution is obtained.

## **4.3 Simulator**

To avoid possible damages of running the actual robots system to test new algorithms, such as new path planners, a simulator is developed. The simulator uses internal physic-based robot models. The physics engine used is Newton Dynamics 2.



Fig.4. Simulator program

## References

- 1- Zickler, S., Vail, D., Levi, G., Wasserman, P., Bruce, J., Licitra, M., Veloso, M.: CMDragons 2008 Team Description. In: Proceedings of RoboCup 2009.
- 2- -Srisabye, J., Hoonsuwan, P., Bowarnkitiwong, S., Onman, C., Wasuntapichaikul, P., Signhakarn, A., et al., Skuba 2009 Team Description of the World RobCup 2008, Kasetsart University, Thailand.
- 3- B.P.T. van Goch, Optimizing a solenoid for a Robocup kicker, University of Technology Eindhoven.
- 4- Ruud Tilburgs, Design and realization of a solenoid for a Robocup kicking device, Technische Universiteit Eindhoven, Department of Mechanical Engineering, Control Systems Technology Group.
- 5- Lenses selection and setup, [www.theimagingsource.com/en](http://www.theimagingsource.com/en).
- 6- Bruce, J., Zickler, S., Licitra, M., Veloso, M.: CMDragons 2007 Team Description. Technical report, Tech Report CMU-CS-07-173, Carnegie Mellon University, School of Computer Science.
- 7- Browning, B., Bruce, J.R., Bowling, M., Veloso, M.: STP: Skills tactics and plans for multi-robot control in adversarial environments. In: Journal of System and Control Engineering.
- 8- Bruce, J.R.: Real-Time Motion Planning and Safe Navigation in Dynamic Multi-Robot Environments. PhD thesis, Carnegie Mellon University
- 9- Bruce, J., Veloso, M.: Real-time randomized path planning for robot navigation. In: Proceedings of IROS-2002, Computer Science Department

Leadwerks Engine, <http://www.leadwerks.com>

- 10- Brett Browning, Gal Kaminka, and Manuela Veloso. Principled Monitoring of Distributed Agents for Detection of Coordination Failure. In Proceedings of DARS-2002, the Seventh International Symposium on Distributed Autonomous Robotic Systems, Fukuoka, Japan, June 2002.
- 11- Sven Behnke, Anna Egorova, Alexander Gloye, Raúl Rojas, and Mark Simon: Predicting away the Delay, in N.N. (editors): RoboCup-2003: *Robot Soccer World Cup VII*, Springer, 2004.